

SERIE NOVA + PLUS

CARATTERISTICHE TECNICHE:	
SEZIONE ANTA:	68x78 MM.
SEZIONE TELAIO:	68x80 MM.
SPESS. VETRO:	28-32 MM.
TRASMITTANZA TERMICA NODI	
NODO LATERALE	1,38 UW
NODO CENTRALE	1,29 UW
NODO INFERIORE FIN.	1,48 UW
NODO INFERIORE P. FIN.	1,63 UW
TRASMITTANZA TERMICA UW	(MISURA 1300X1500)
3+3 / 15 / 3+3 BE	1,67 UW
3+3 / 15 ARGON / 3+3 BE	1,56 UW
3+3 / 15 ARGON SW/3+3 BE	1,47 UW
(SW = SWISSPACER)	
ABBATIMENTO ACUSTICO	
VETRO 5+5 / 12 / 3+3 SS	40 DB
FERRAMENTA DI SERIE	ANTA RIBALTA
FERRAMENTA OPTIONAL	ANUBA DOPPIO GAMBO
GOCCIOLATOIO ALLUM.	DI SERIE
GOCCIOLATOIO IN LEGNO	OPTIONAL
GARANZIA VERN. 5 ANNI	DI SERIE
GARANZIA VERN. 10 ANNI	OPTIONAL

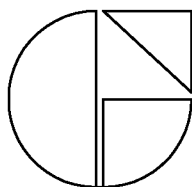

GASPARRINI M.B.M. SRL
 VIA MARGONI, 19
 62010 APPIGNANO
 (MC) ITALY

CARATTERISTICHE
 TECNICHE NOVA +

SERIE NOVA + PLUS

PROVE DI LABORATORIO

FINESTRA

RESISTENZA AL VENTO

TENUTA ALL'ACQUA

PERMEABILITA' ALL'ARIA

UNI EN 12210 - C4

UNI EN 12208 E750

UNI EN 12207 4

PORTA FINESTRA

RESISTENZA AL VENTO

TENUTA ALL'ACQUA

PERMEABILITA' ALL'ARIA

UNI EN 12210 - C2

UNI EN 12208 5A

UNI EN 12207 4

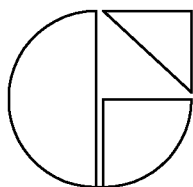

GASPARRINI M.B.M. SRL
VIA MARGONI, 19
62010 APPIGNANO
(MC) ITALY

CARATTERISTICHE
TECNICHE NOVA +

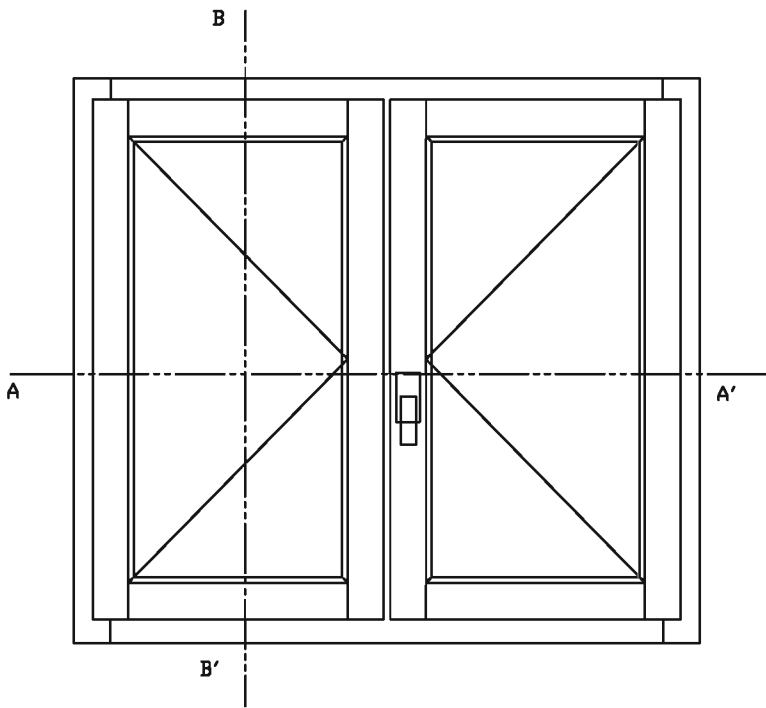

CARATTERISTICHE TECNICHE:
SEZIONE ANTA: 68X78 MM.
SEZIONE TELAIO: 68X80 MM.
SPESSORE VETRO: 28 MM.

Sezione B-B'

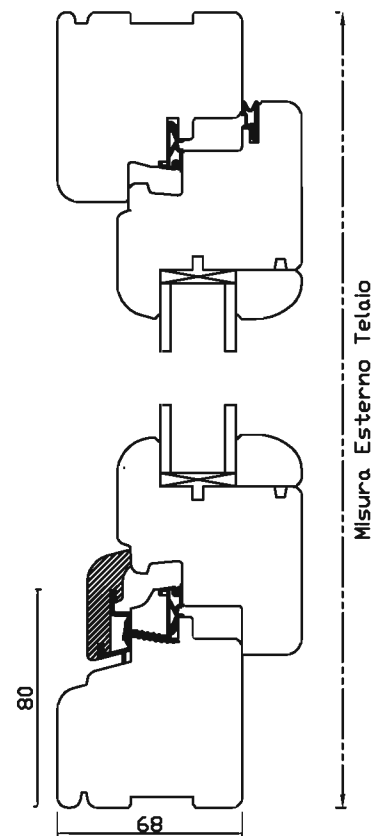

IMPORTANTE: LA DITTA SI RISERVA LA FACOLTA' DI APPORTARE MODIFICHE SENZA DARNE PREAVVISO.

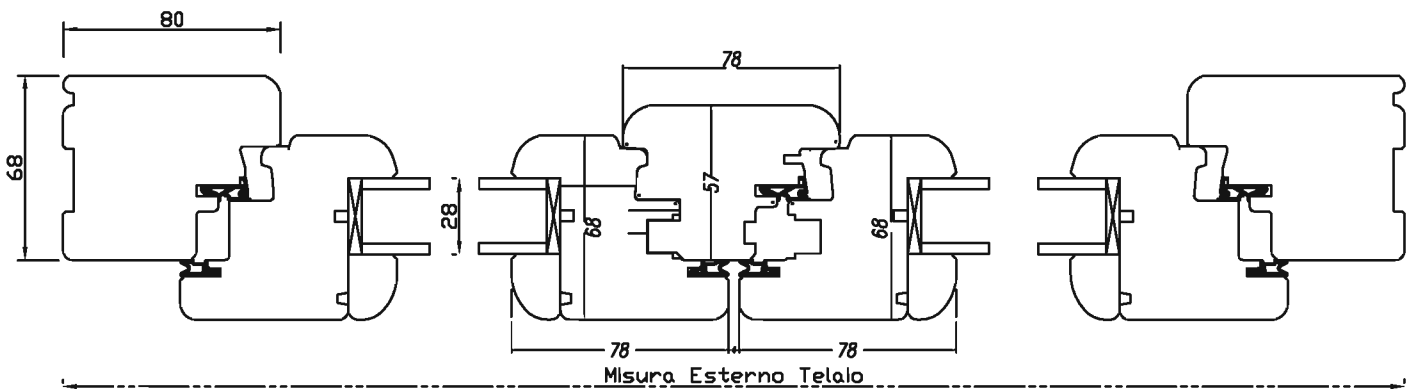

Sezione A-A'

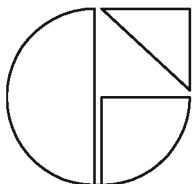

GASPARRINI M.B.M. SRL
 VIA MARCONI, 19
 62010 APPIGNANO
 (MC) ITALY

SERRAMENTO TIPO:
 NOVA + LEGNO

Tav. Al

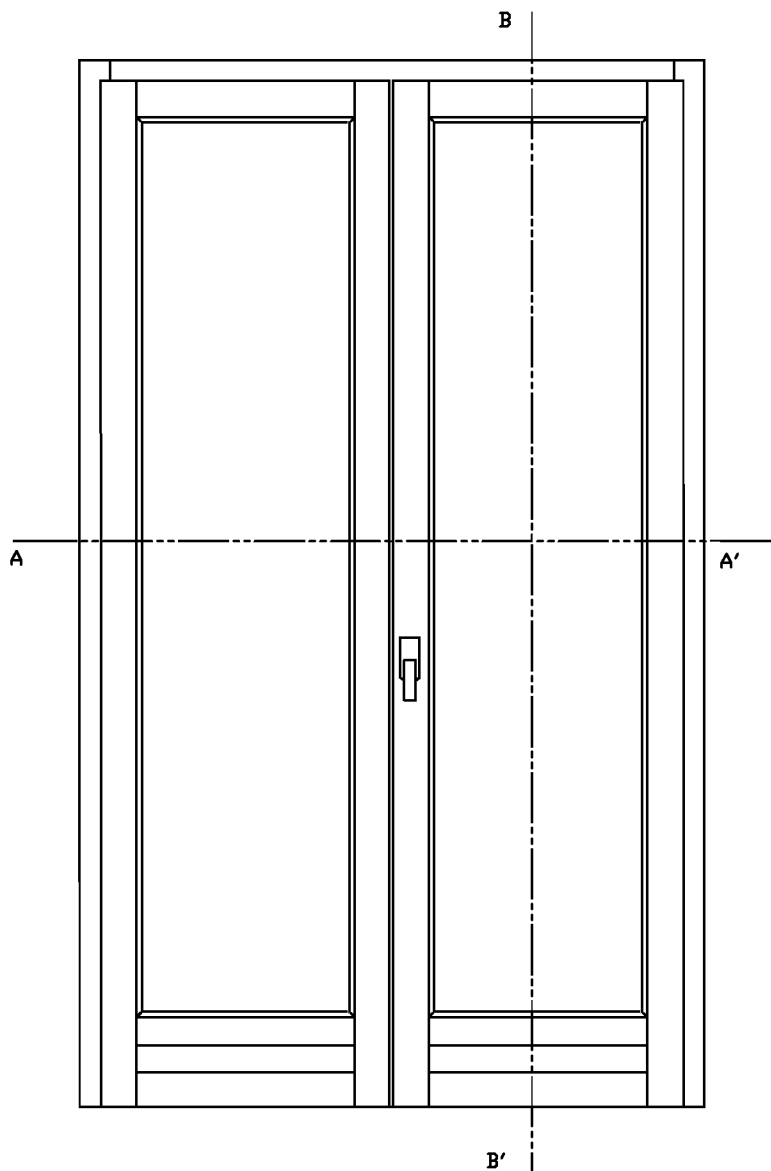

CARATTERISTICHE TECNICHE:
SEZIONE ANTA: 68X78 MM.
SEZIONE TELAIO: 68X80 MM.
SPESSORE VETRO: 28 MM.

Sezione B-B'

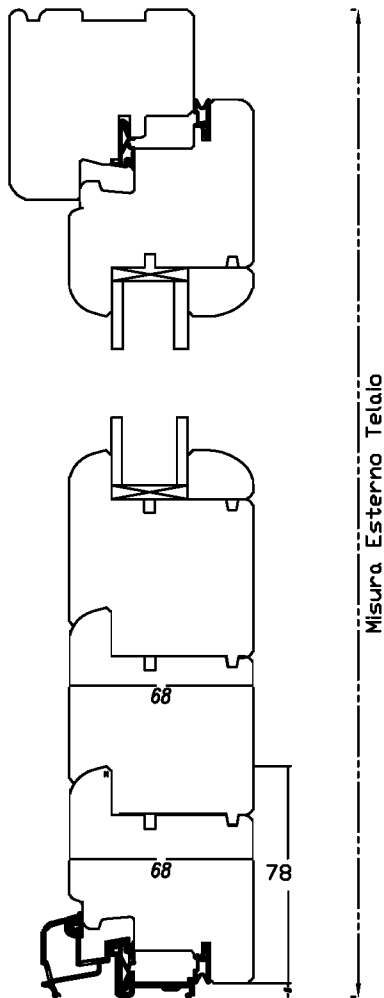

IMPORTANTE: LA DITTA SI RISERVA LA FACOLTA' DI APPORTARE MODIFICHE SENZA DARNE PREAVVISO.

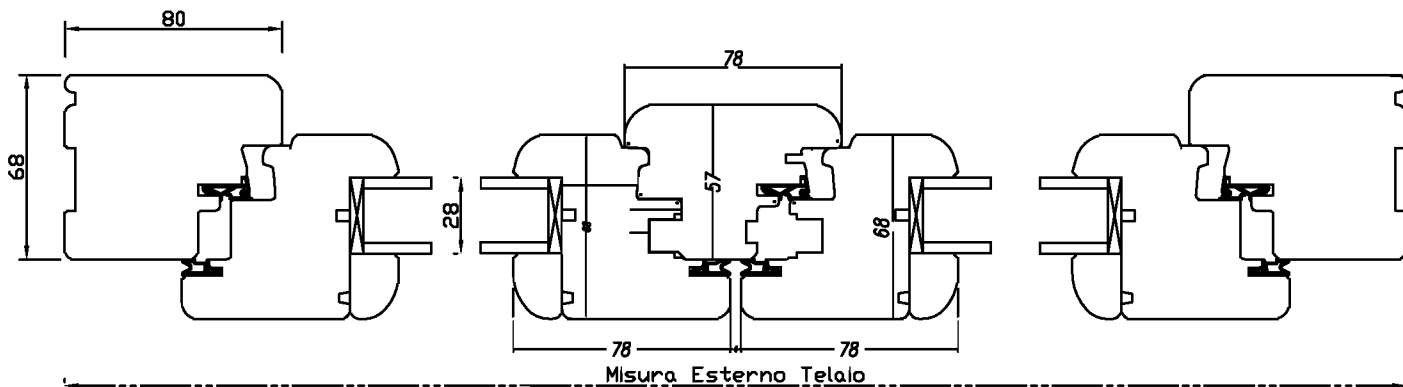

Sezione A-A'

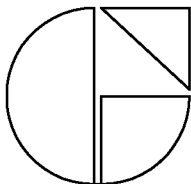

GASPARRINI M.B.M. SRL
 VIA MARGONI, 19
 62010 APPIGNANO
 (MC) ITALY

SERRAMENTO TIPO:
 NOVA + LEGNO
 PORTA FINESTRA SENZA
 TRAVERSO

Tav. A2

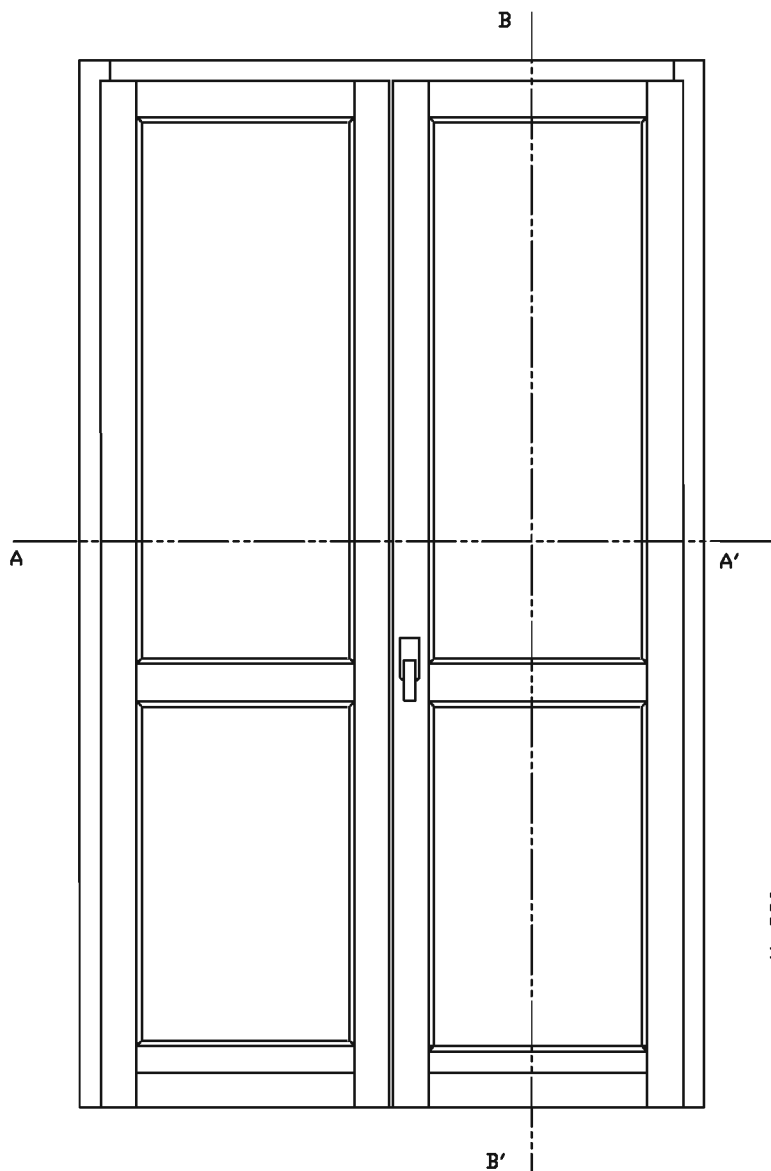

CARATTERISTICHE TECNICHE:
SEZIONE ANTA: 68X78 MM.
SEZIONE TELAIO: 68X80 MM.
SPESSORE VETRO: 28 MM.

Sezione B-B'

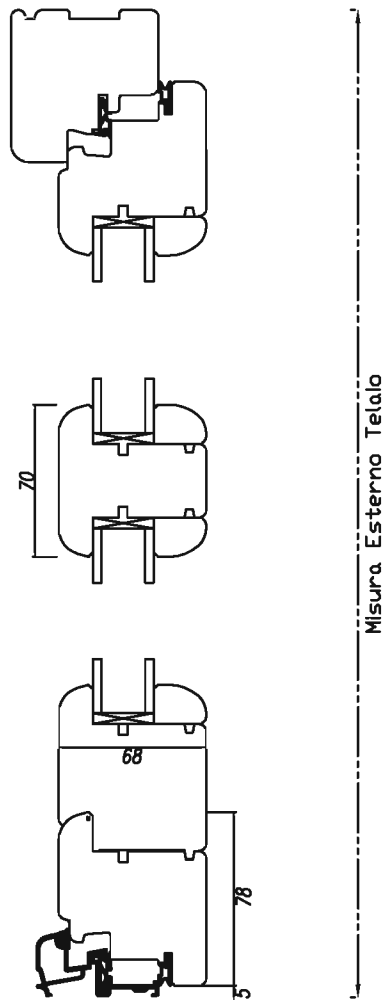

IMPORTANTE: LA DITTA SI RISERVA LA FACOLTA' DI APPORTARE MODIFICHE SENZA DARNE PREAVVISO.

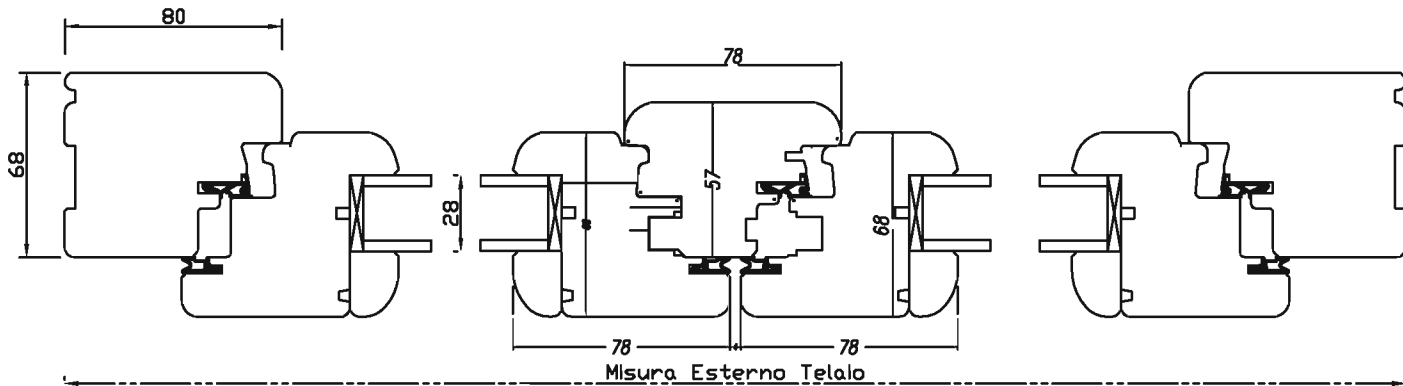

Sezione A-A'

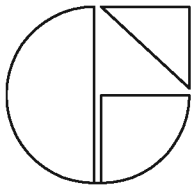

GASPARRINI M.B.M. SRL
 VIA MARGONI, 19
 62010 APPIGNANO
 (MC) ITALY

SERRAMENTO TIPO:
 NOVA + LEGNO
 PORTA FINESTRA SENZA
 TRAVERSO

Tav. A3

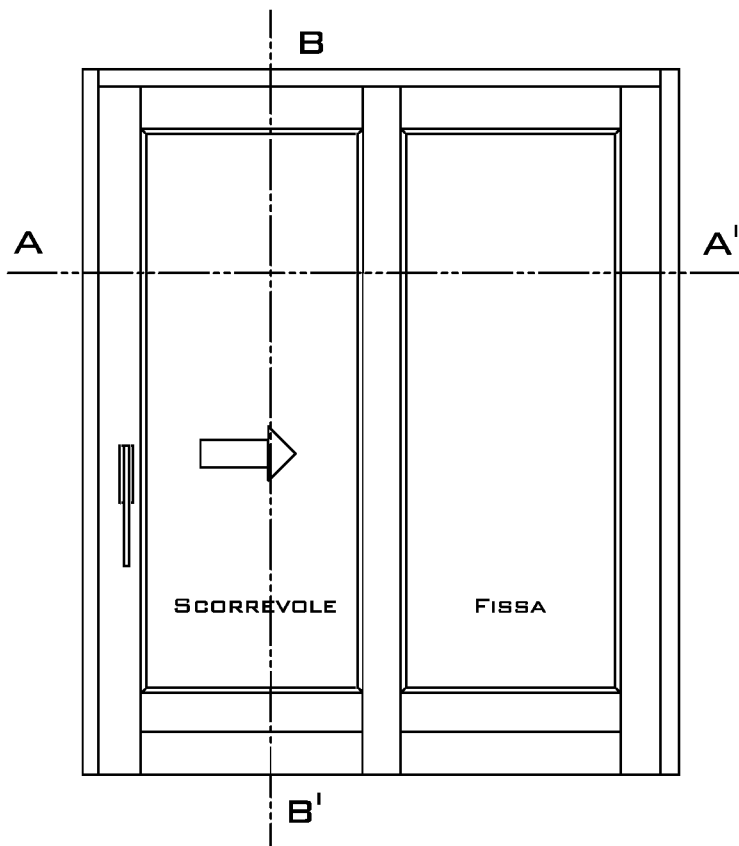

CARATTERISTICHE TECNICHE:
SEZIONE ANTA: 68X110 MM.
SEZIONE TEL.: 50X180 MM.
SPESSORE VETRO: 28 MM.

SEZIONE B-B'

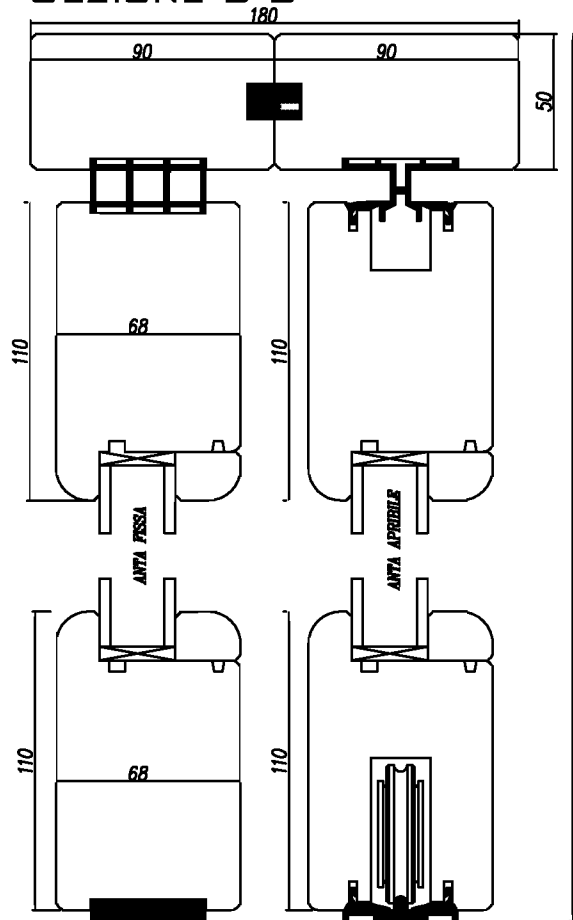

IMPORTANTE: LA DITTA SI RISERVA LA FACOLTA' DI APPORTARE MODIFICHE SENZA DARNE PREAVVISO.

SEZIONE A-A'

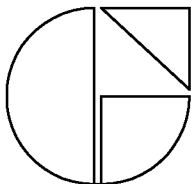
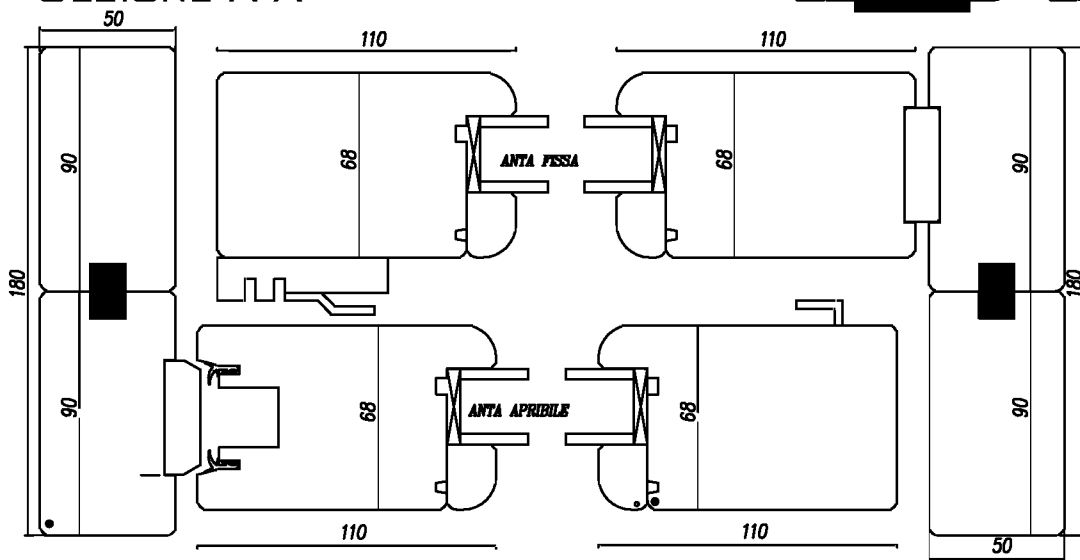

GASPARRINI M.B.M. SRL
 VIA MARGONI, 19
 62010 APPIGNANO
 (MC) ITALY

**SERIE NOVA +
 ALZANTE
 SCORREVOLE**

Tav. A4

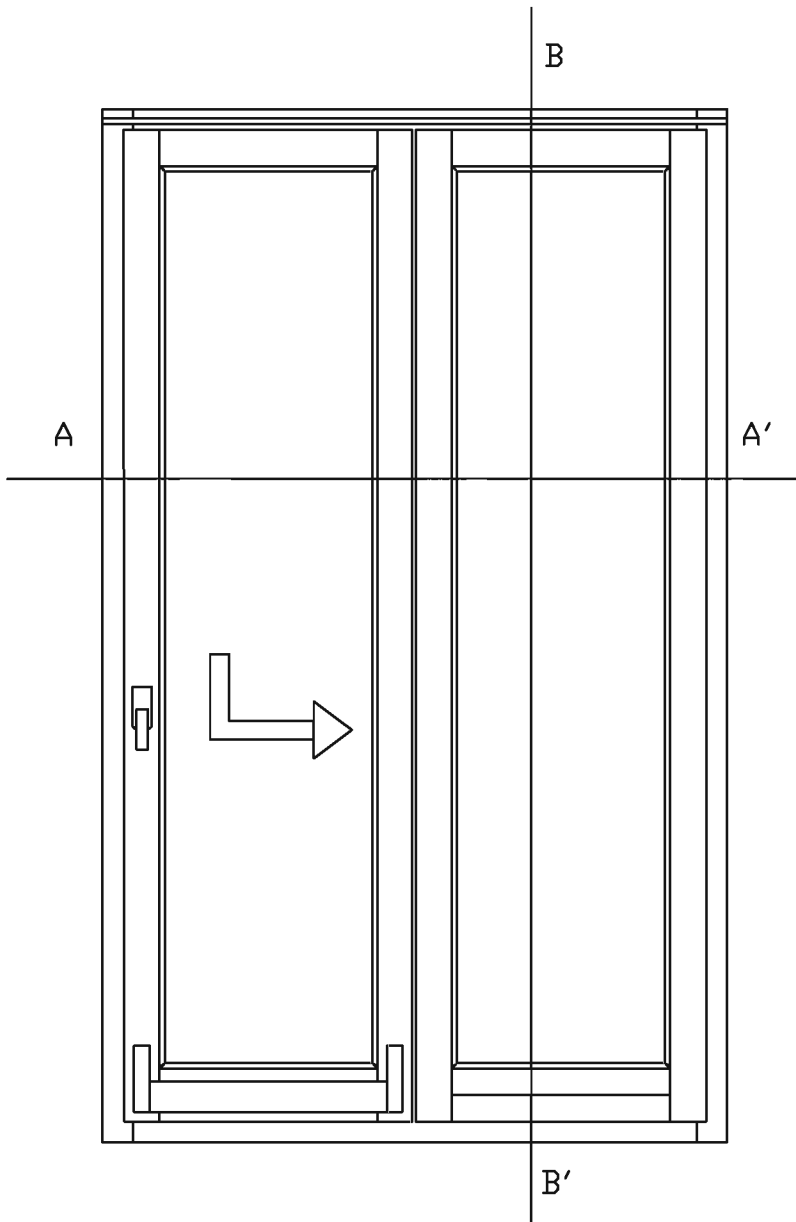

CARATTERISTICHE TECNICHE:
SEZIONE ANTA: 68x78 MM.
SEZIONE TELAIO: 68x80 MM.
SPESSORE VETRO: 28 MM.

Sezione B-B'

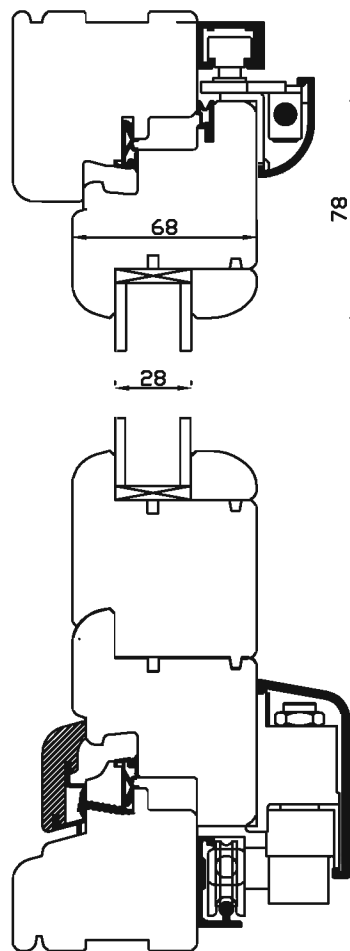

IMPORTANTE: LA DITTA SI RISERVA LA FACOLTA' DI APPORTARE MODIFICHE SENZA DARNE PREAVVISO.

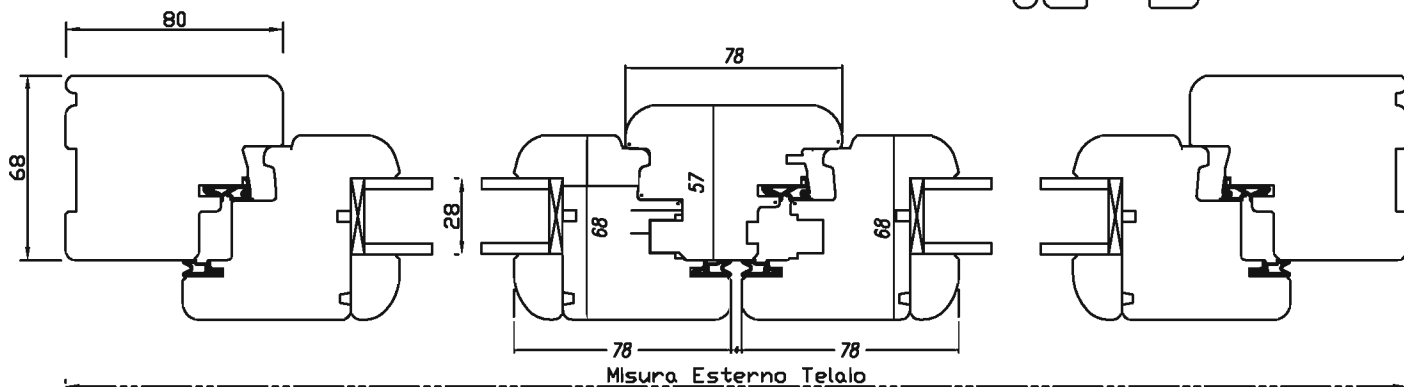

Sezione A-A'

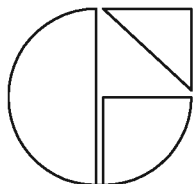

GASPARRINI M.B.M. SRL
 VIA MARGONI, 19
 62010 APPIGNANO
 (MC) ITALY

SERRAMENTO TIPO:
 NOVA + LEGNO
 SCORREVOLE PARALLELO

Tav. A5

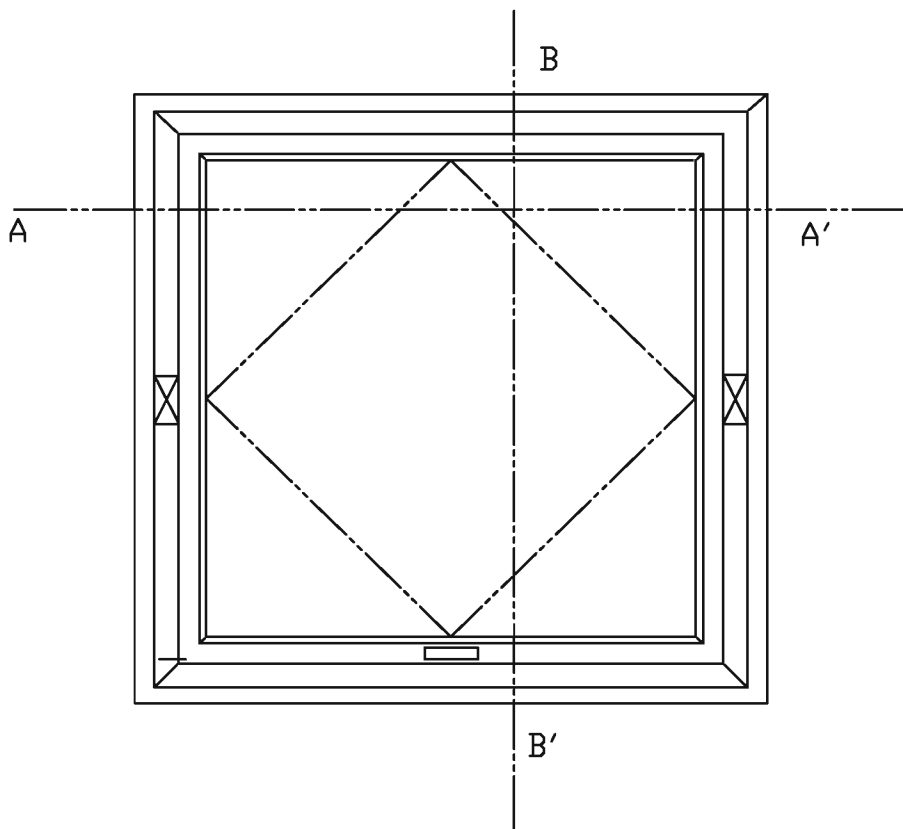

CARATTERISTICHE TECNICHE:
SEZIONE ANTA: 68X78 MM.
SEZIONE TELAIO: 68X80 MM.
SPESSORE VETRO: 28 MM.

Sezione B-B'

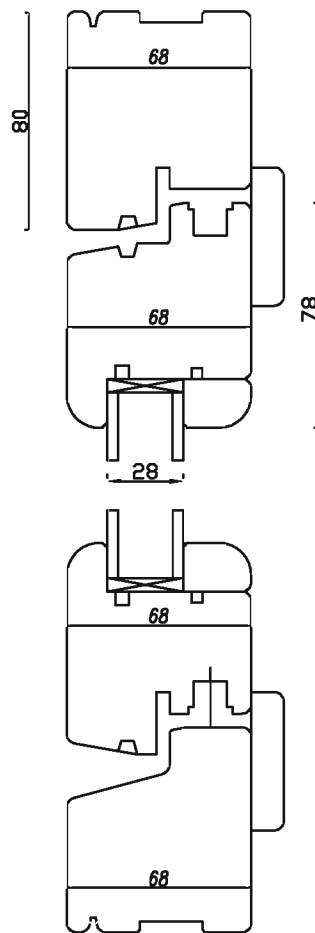

IMPORTANTE: LA DITTA SI RISERVA LA FACOLTA' DI APPORTARE MODIFICHE SENZA DARNE PREAVVISO.

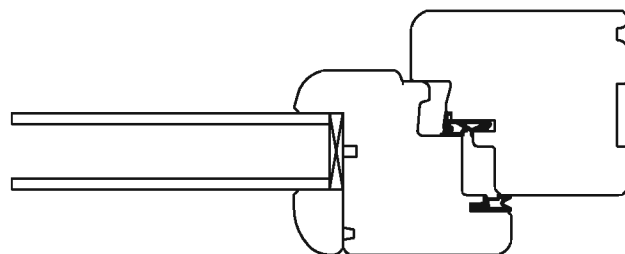
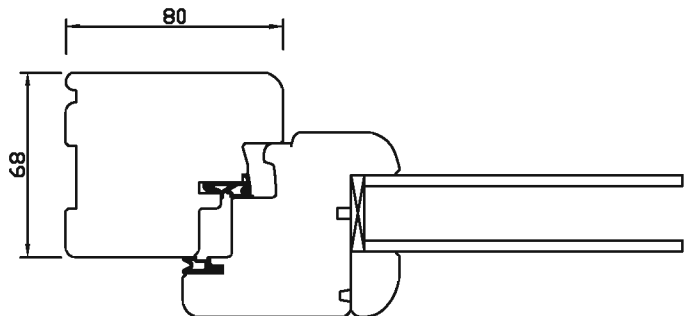

Misura Esterno Telaio

Sezione A-A'

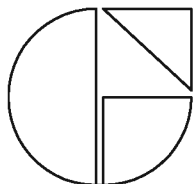

GASPARRINI M.B.M. SRL
 VIA MARGONI, 19
 62010 APPIGNANO
 (MC) ITALY

SERRAMENTO TIPO:
 NOVA + LEGNO
 BILICO Kg. 200

Tav. A6

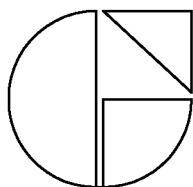
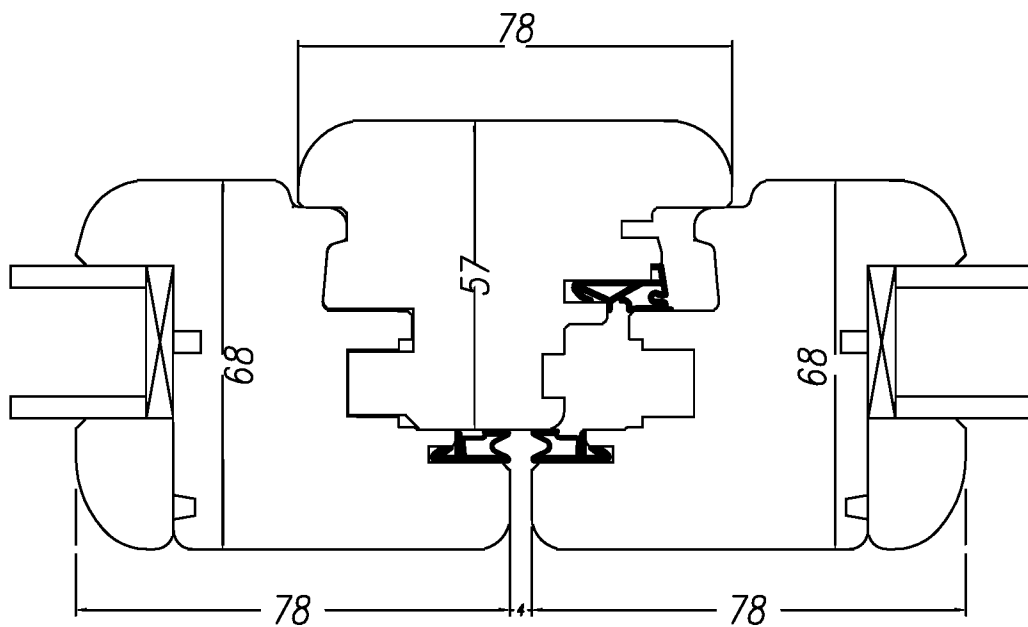
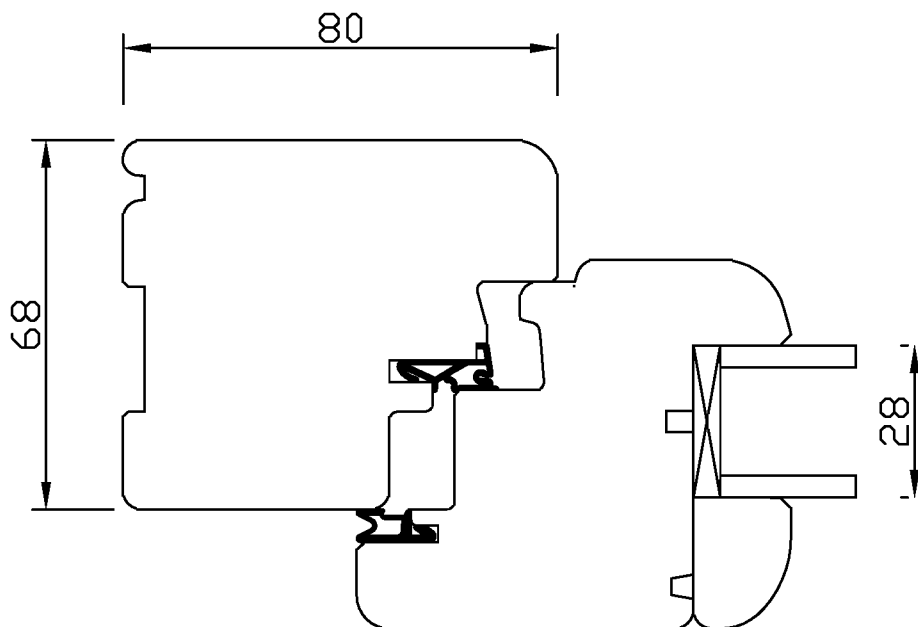

GASPARRINI M.B.M. SRL
VIA MARGONI, 19
62010 APPIGNANO
(MC) ITALY

NODI
SERIE NOVA +

Tav. A7

Soluzione 1

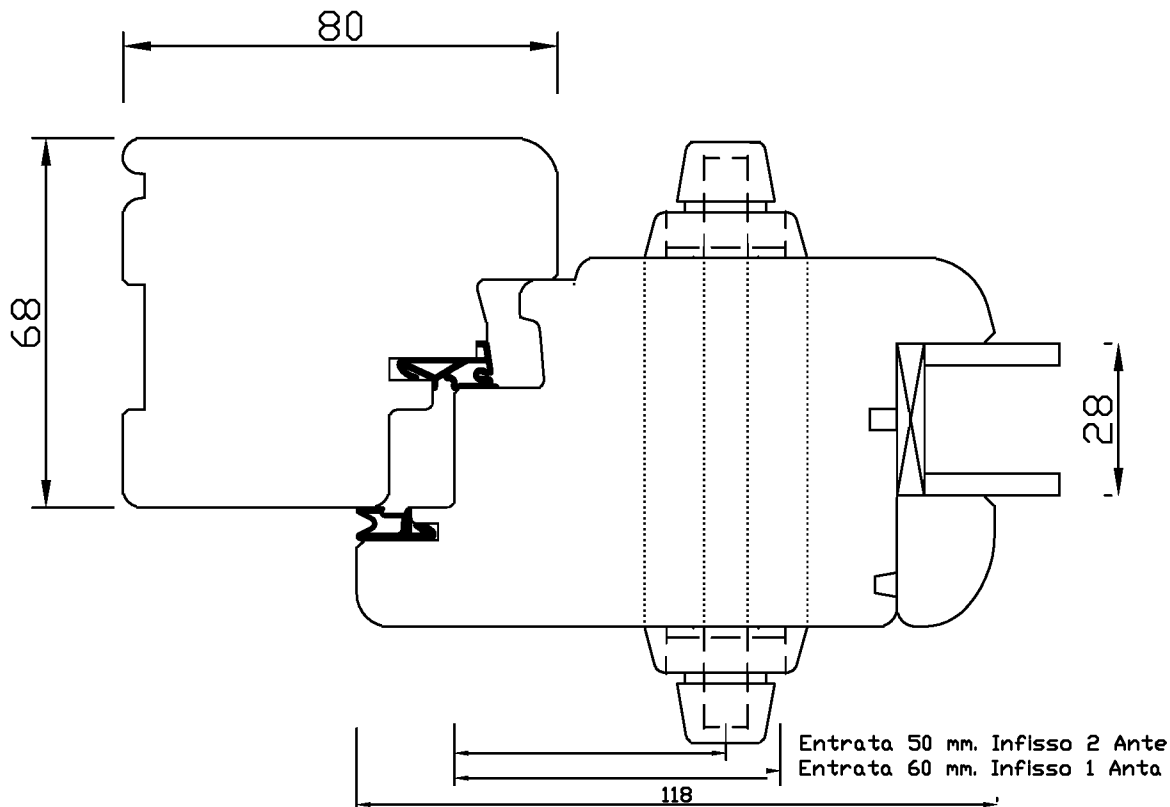

Soluzione 2 Standard

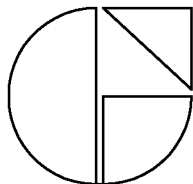
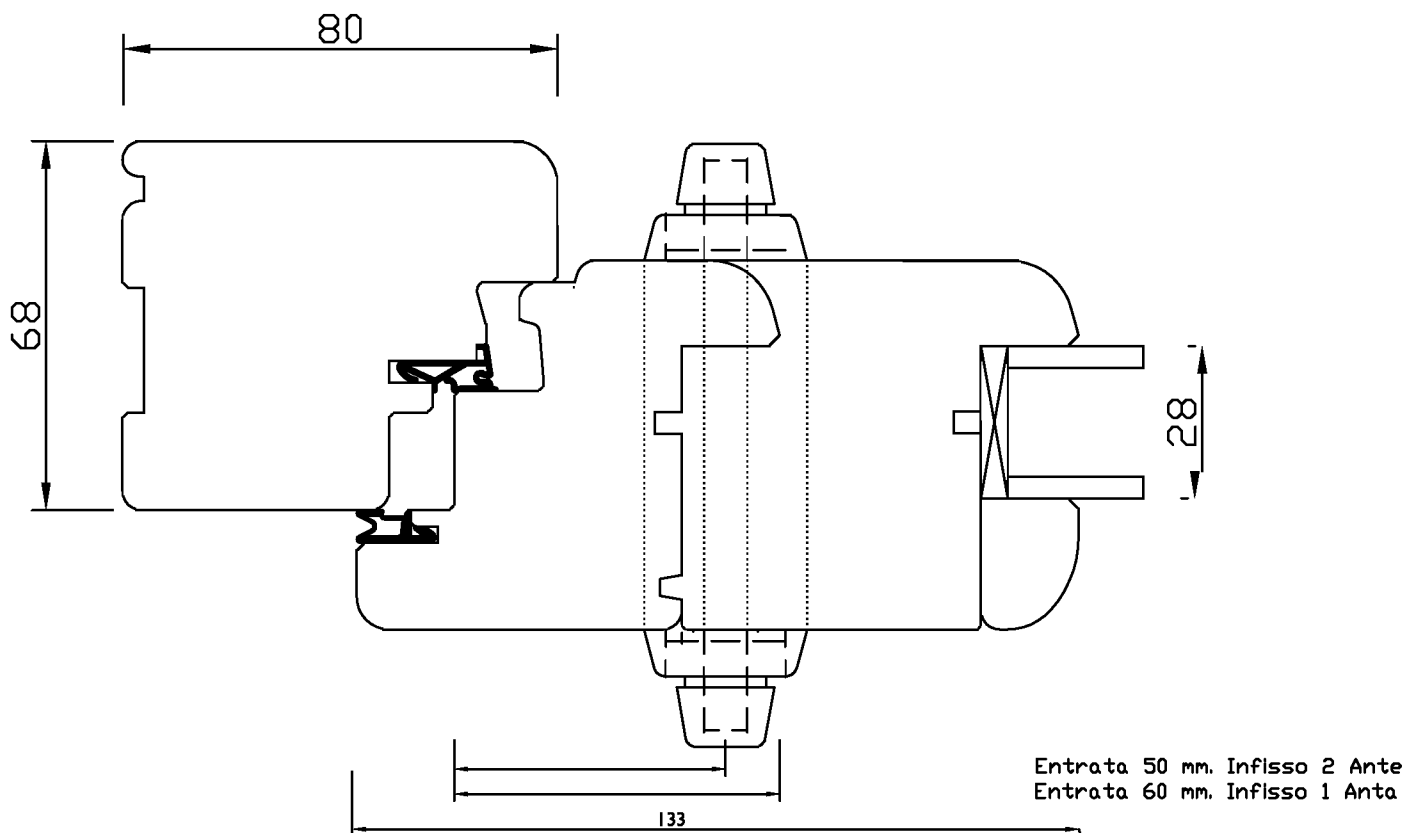

GASPARRINI M.B.M. SRL
VIA MARGONI, 19
62010 APPIGNANO
(MC) ITALY

NODI
SERIE NOVA +
MONTANTI YALE

Tav. A8

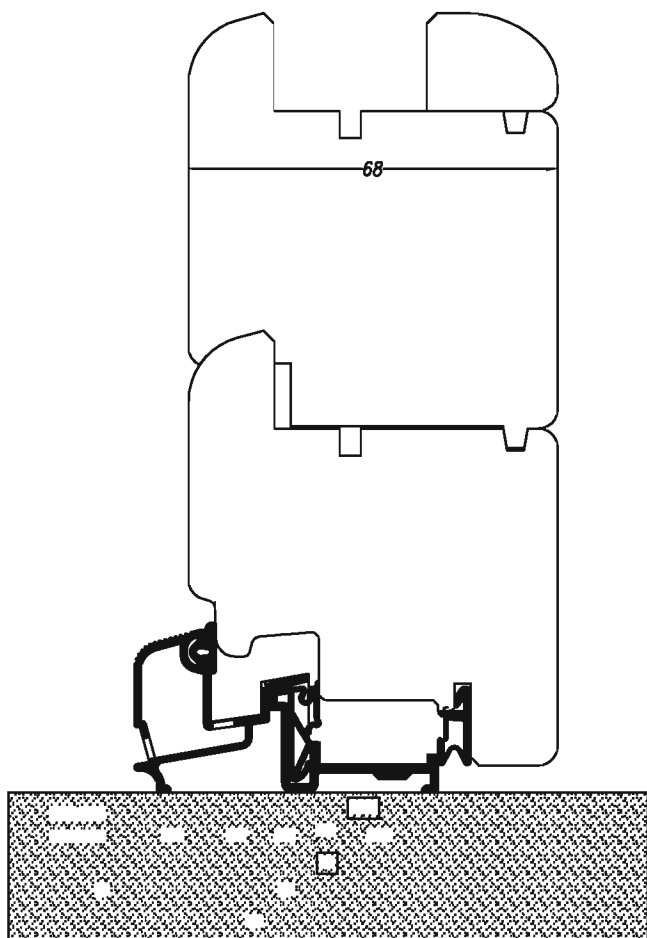

Soluzione Standard

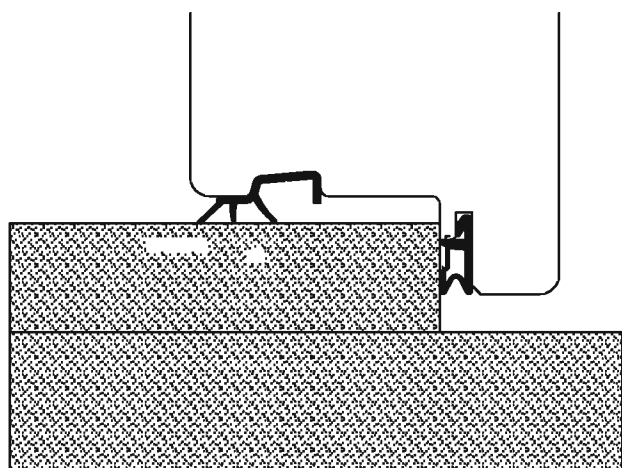

Soluzione con Battuta Marmo (Non Certificata)

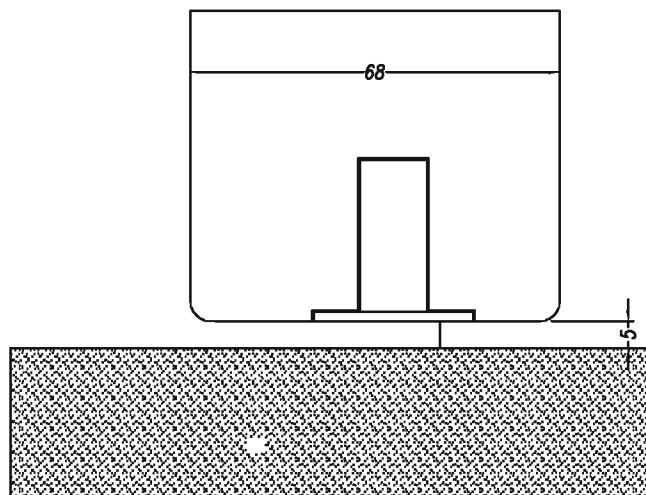

Soluzione con Soglia Parafreddo (Non Certificata)

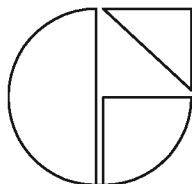

GASPARRINI M.B.M. SRL
VIA MARGONI, 19
62010 APPIGNANO
(MC) ITALY

NODI INFERIORI
SERIE NOVA +

Tav. A9

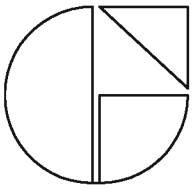
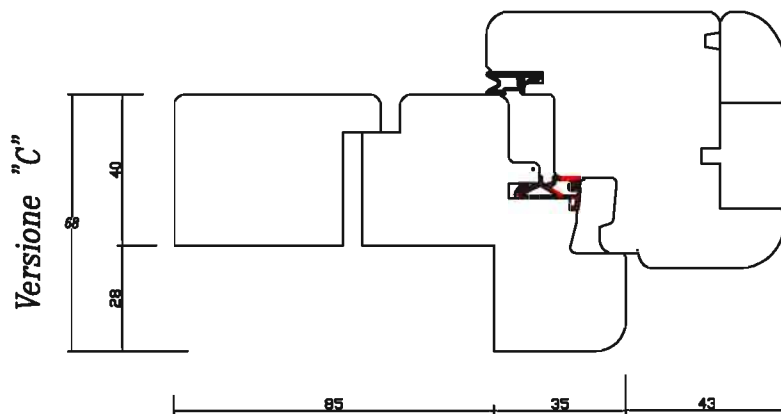
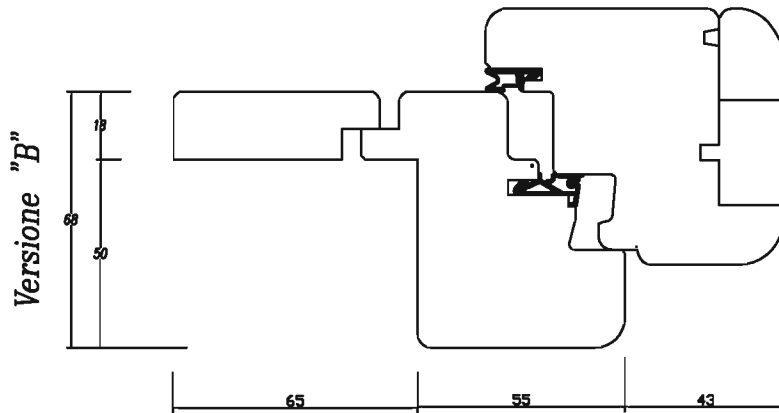
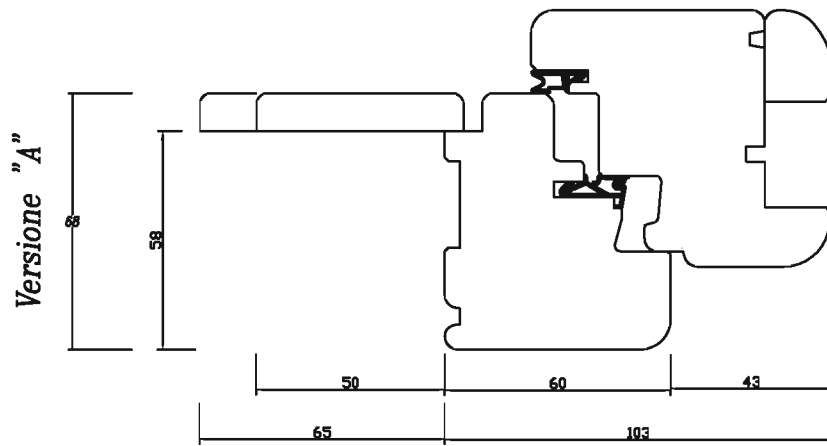

GASPARRINI M.B.M. SRL
VIA MARCONI, 19
62010 APPIGNANO
(MC) ITALY

TELAIO TIPO
RISTRUTTURAZIONE

Tav. A10

Novità
2010